

SCHWARZWALDMÜHLE

BLACK FOREST MILL
MOULIN DE LA FORÊT-NOIRE
ZWARTE WOOD MOLEN



Art. Nr. 190071/2

D

Vor Beginn des Bastelns sollten Sie sich mit den Spritzlingen und der Anleitung vertraut machen. Sollte es einmal vorkommen, dass ein Teil im Bausatz fehlt, kreuzen Sie bitte das fehlende Teil in der Anleitung an und schicken Sie diese bitte an Fa. Gebr. FALLER GmbH, Abt. Kundendienst, kundendienst@faller.de, Kreuzstraße 9, 78148 Gütenbach. Sie erhalten dann umgehend Ersatz. Es kann vorkommen, dass bei einem Bausatz Einzelteile übrig sind.

GB

Before beginning with the assembly please familiarize yourself with the parts and read the instructions carefully. In case of missing parts please indicate these on the instructions leaflet with a circle and return the leaflet to Gebr. FALLER GmbH, kundendienst@faller.de, Kreuzstraße 9, D-78148 Gütenbach, Germany. You will receive the replacement by return. It may happen in a kit that some parts are not required.

F

Avant de commencer le montage de votre maquette bien lire la notice et repérer les grappes. Si une pièce manque dans une boîte, cochez la pièce correspondante sur la notice et renvoyez-la-nous à Gebr. FALLER GmbH, kundendienst@faller.de, Kreuzstraße 9, D-78148 Gütenbach (R.F.A.). Nous vous ferons parvenir la pièce par retour. Dans certains kits, il est possible que certaines pièces ne soient pas utilisées.

NL

Vóór het bouwen zou men de gietstukken en de handleiding moeten bestuderen. Indien onverhoopt een onderdeel aan het bouwpakket ontbreekt, gelieve men het ontbrekende deel in de handleiding aan te kruisen en deze te zenden aan Gebr. FALLER GmbH, kundendienst@faller.de, Kreuzstraße 9, D-78148 Gütenbach. U ontvangt dan omgaand en gratis het ontbrekende onderdeel. Het kan voorkomen dat u bij bepaalde bouwdozen onderdelen overhoudt.

Für den Zusammenbau des Modells empfehlen wir folgende FALLER-Artikel (sind nicht im Bausatz enthalten):
For the assembly of the kit we recommend following FALLER products (not included in the kit):
Pour l'assemblage du modèle, nous vous recommandons les articles FALLER suivants (non inclus dans le kit):
Om dit model te bouwen adviseren wij de volgende FALLER producten (maken geen deel uit van deze bouwset):



Art. Nr. 170492
FALLER-EXPERT

Flüssigkleber in Plastikflasche mit Spezialkanüle für feinste Klebstoffdosierung.

Liquid cement in plastic bottle with canule for very fine dosage.

Celle liquide en bouteille plastique avec bec verseur pour un dosage précis.

Vloeibare lijm in plastic-fles met doseerbuisje om nauwkeurig te lijmen.



Art. Nr. 170688
SPEZIAL-SEITENSCHNEIDER

zum geratfreien Abtrennen von feinsten Spritzteilen.
Nur für Polystyrol geeignet.

Special side cutter for cutting off ultra-fine moulded parts without burrs.
Only suitable for polystyrene.

Pince coupante spéciale pour couper sans bavure les pièces miniatures moulées par injection. Convient uniquement au polystyrène.

Speciale zijknijplang voor het braamloos afknippen van de fijnste gietstukdelen. Alleen geschikt voor polystyrol.



Inhalt	Spritzlinge	1	1	x	4	1	x	7	1	x	10	1	x
Contents	Sprues	2	1	x	5	1	x	8	1	x			
Contenu	Moulages												
Inhoud	Gietstukken	3	1	x	6	1	x	9	1	x			

Sa. Nr. 112 147 0

2 Die Teilenummerierung der Spritzteile befindet sich **hier** auf **Seite 2** und auf **Seite 7**.
Die **Seiten 3 bis 6** können zur besseren Übersicht bei der Montage herausgenommen werden.

La numérotation des pièces moulées se trouve **ici** à la **page 2** et la **page 7**.
Pour avoir un meilleur aperçu les **pages 3 à 6** peuvent être retirées pour le montage.

For part numbering of the moulded parts see **page 2** and **page 7**.
Pages 3 to 6 can be removed for better overview during assembly.

De nummering van de delen van de spuitgietstukken staan **hier** op **blz. 2** en op **blz. 7**.
Voor een beter overzicht bij de montage kunnen de **blz. 3 tot 6** eruitgehaald worden.

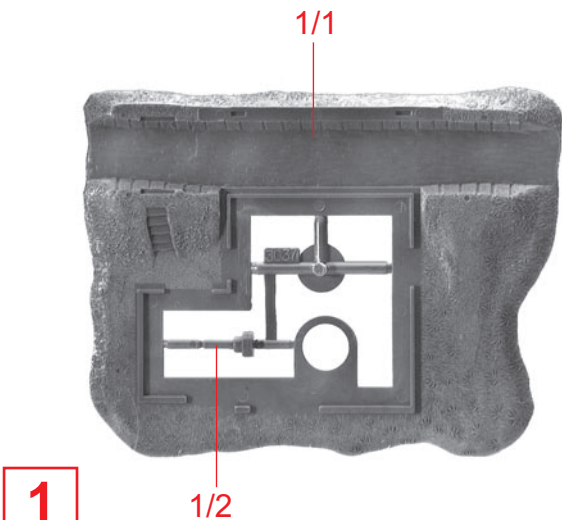

1

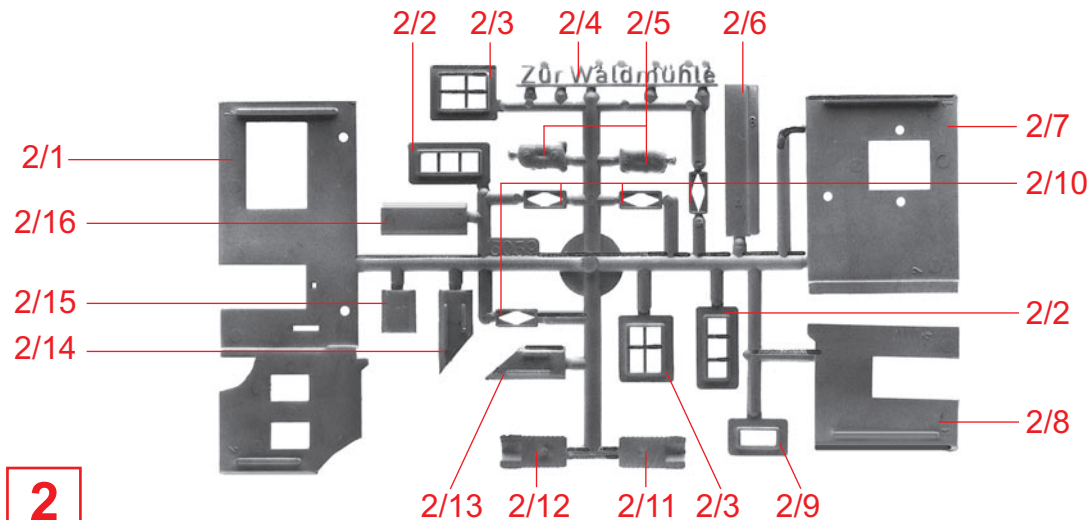

2

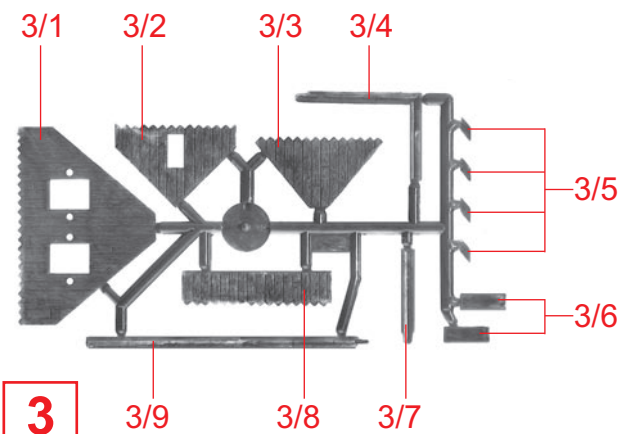

3

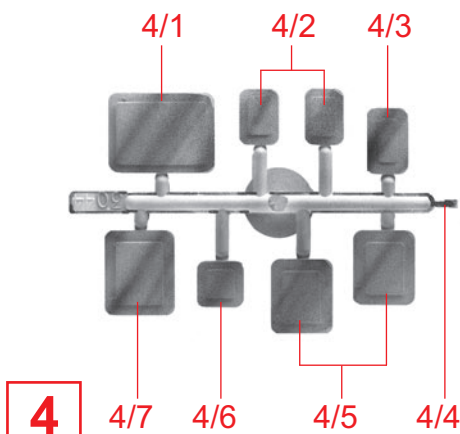

4

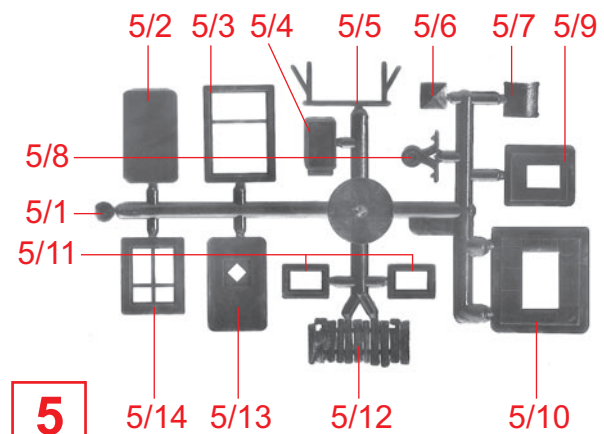

5

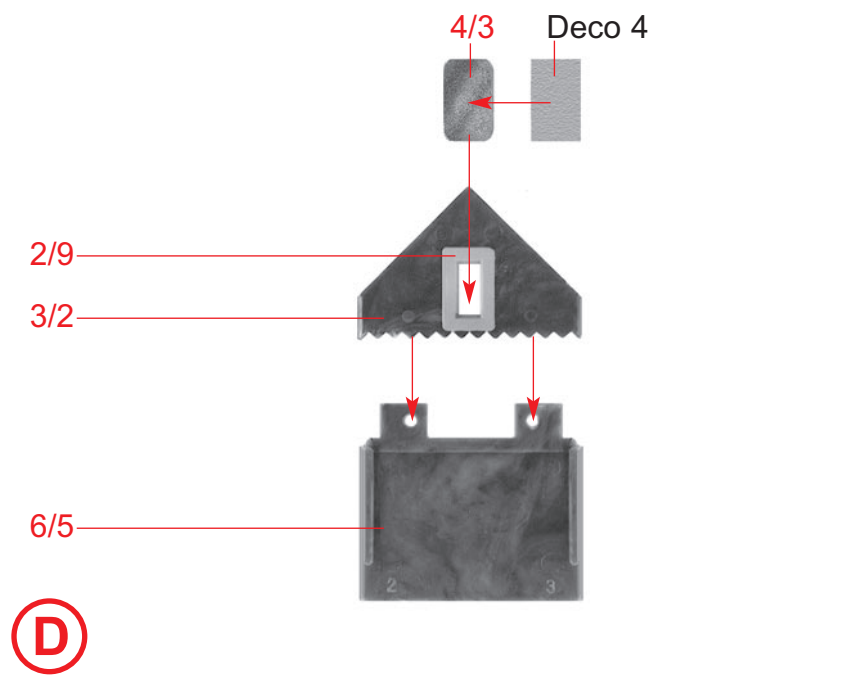
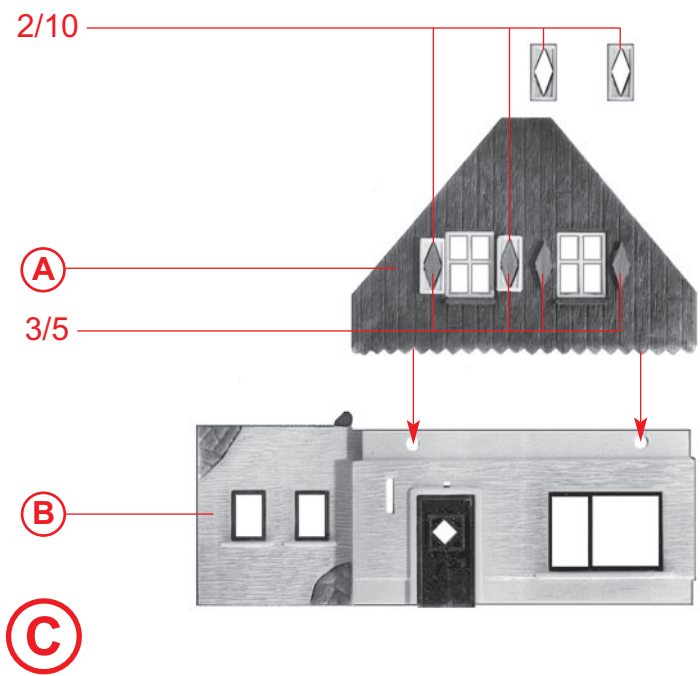
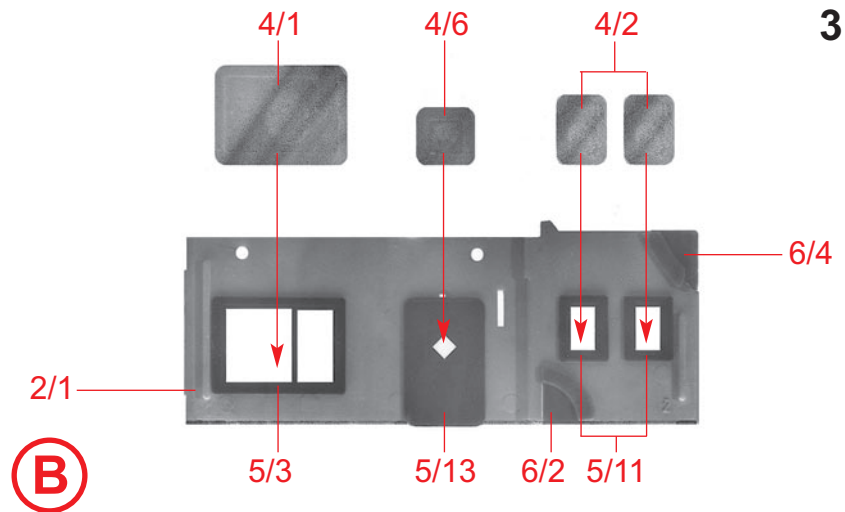
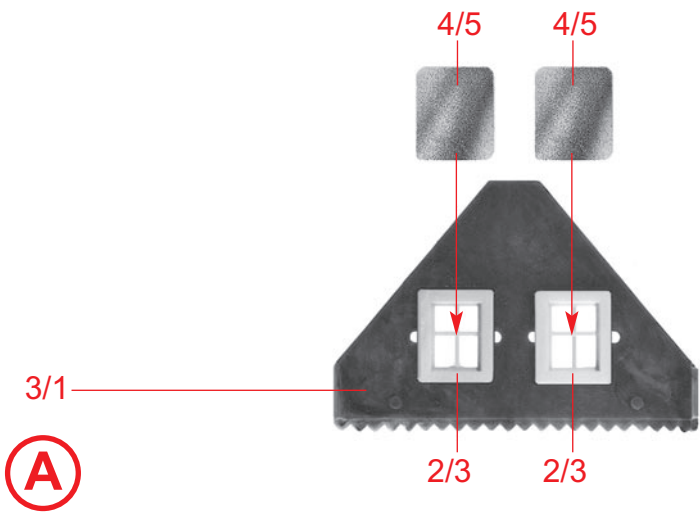

4

4/7



2/7

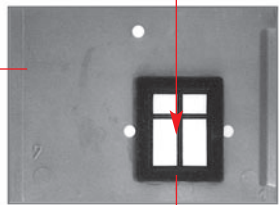

5/14

(E)

3/8



(E)

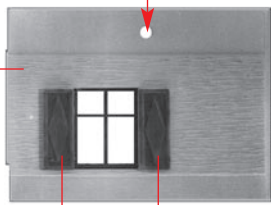

3/6

(F)

Deco 2



2/2

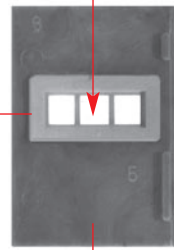

6/6

(G)

Deco 2

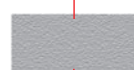

2/2

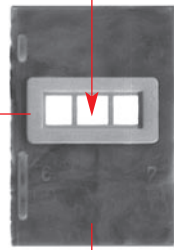

6/7

(H)

2/8

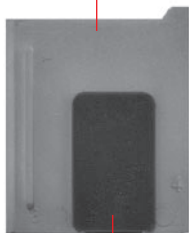

5/2

(I)

(D)

(I)

2/6

(G)

6/8

(C)

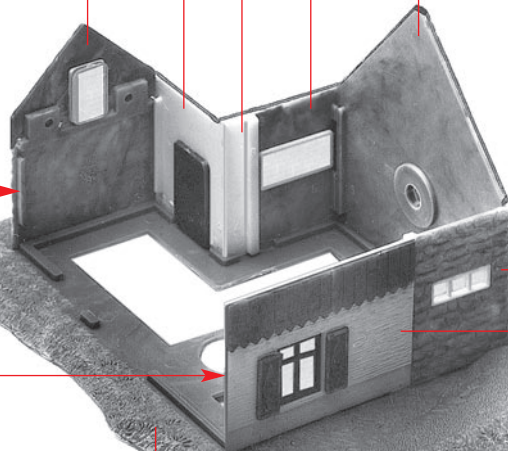
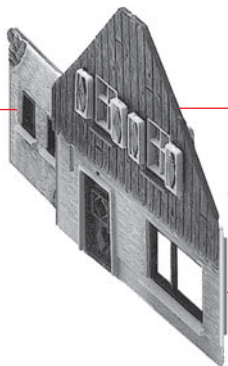

(H)

(F)

(J)

1/1

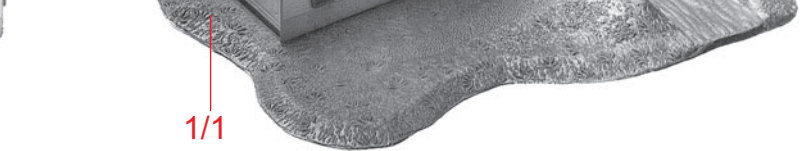

7/1

7/2

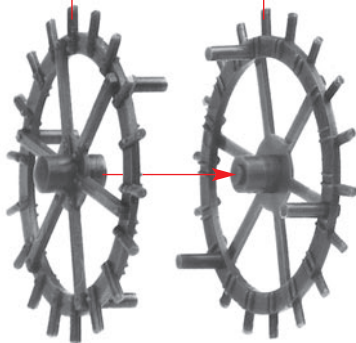

K

18 x 8/1

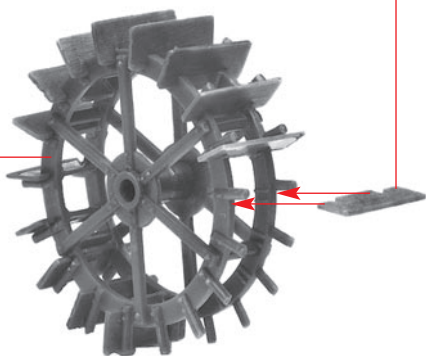

K

L

Variante:
Montage ohne Motor
Assembly without motor
Montage sans moteur
Montage zonder motor

1/2

Papiermaske
Papermask
Masque
Masker

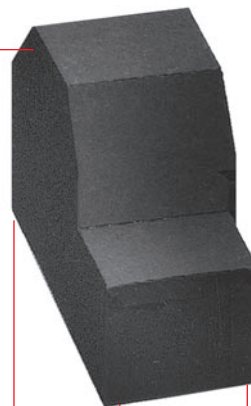

nicht kleben
do not glue
ne pas coller
niet lijmen

Deco 1

nicht kleben
do not glue
ne pas coller
niet lijmen

L

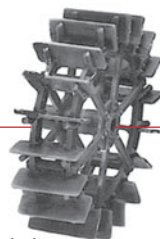

Art. Nr. 180667:
Beleuchtung, liegt nicht bei
Illumination, not included
Eclairage, non jointe
Verlichting, niet bijgevoegd

M

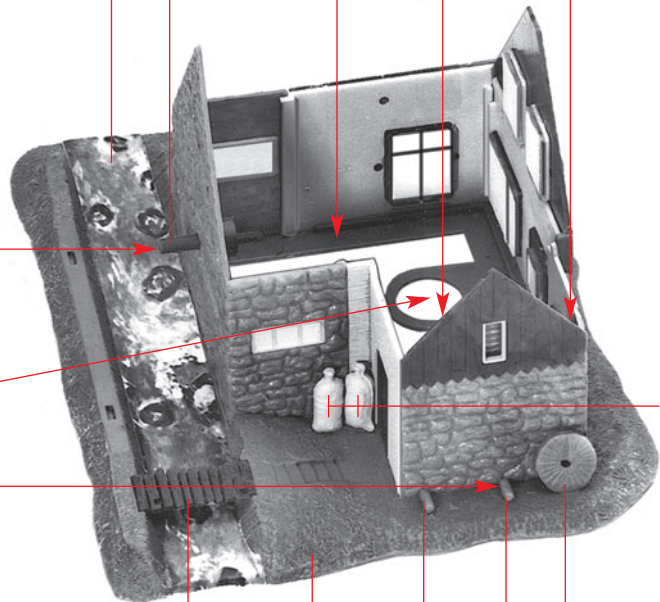

2/5

10/4

5/12

J

10/6

6/3

6

Variante:
Montage mit Motor 180629 (liegt nicht bei);
Teil 1/2 entfällt.

Assembly with motor 180629(not included);
part 1/2 is not needed.

Montage avec moteur 180629 (non jointe);
pièce 1/2 n'est pas utilisée.

Montage met motor 180629 (niet bijgevoegd);
deel 1/2 wordt niet gebruikt.

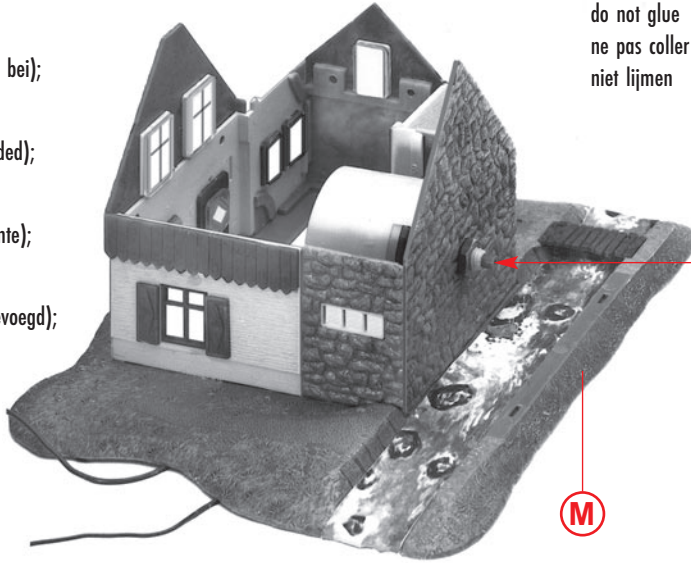

nicht kleben
do not glue
ne pas coller
niet lijmen

L

10/13

10/5



10/5

10/13

O

N

M

6/1

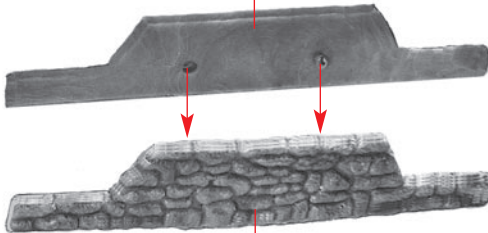

6/1

P

10/10

5/8

5/5

10/6

O

10/9

Q

N

P

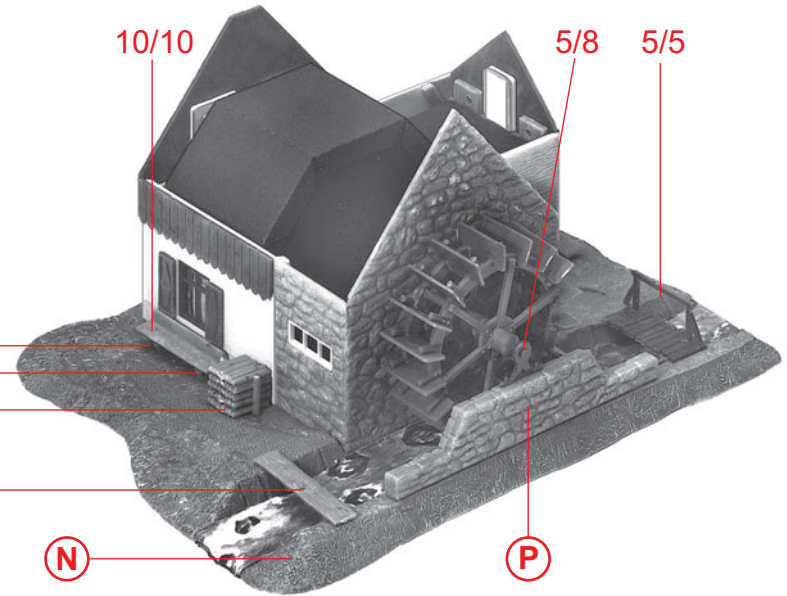

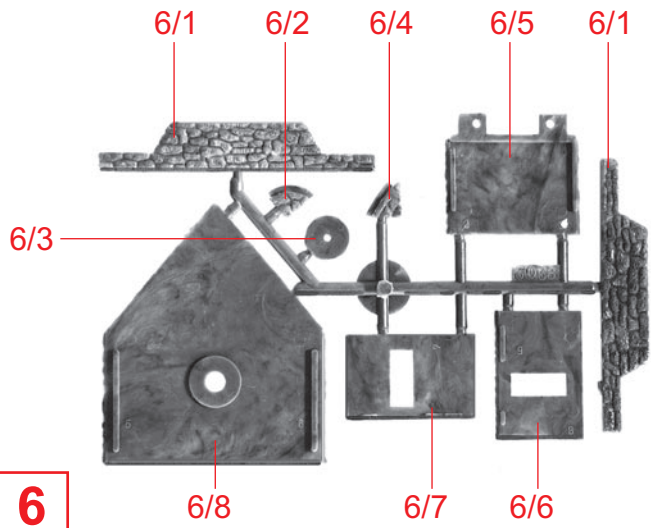

6

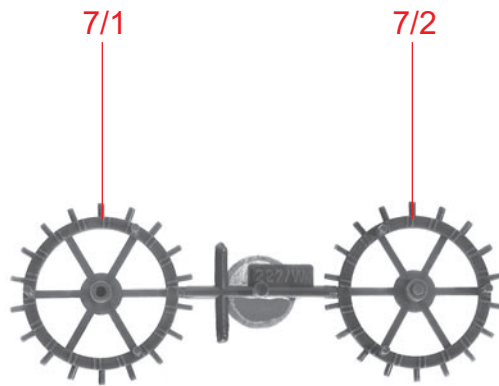

7

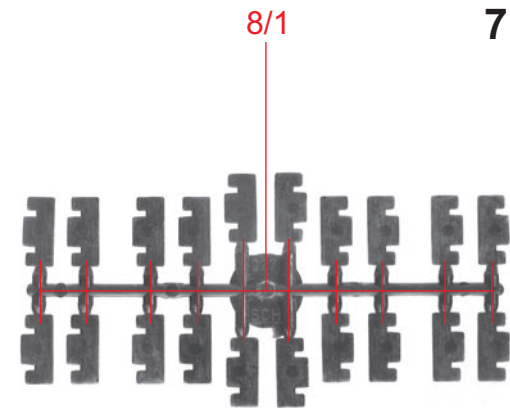

8

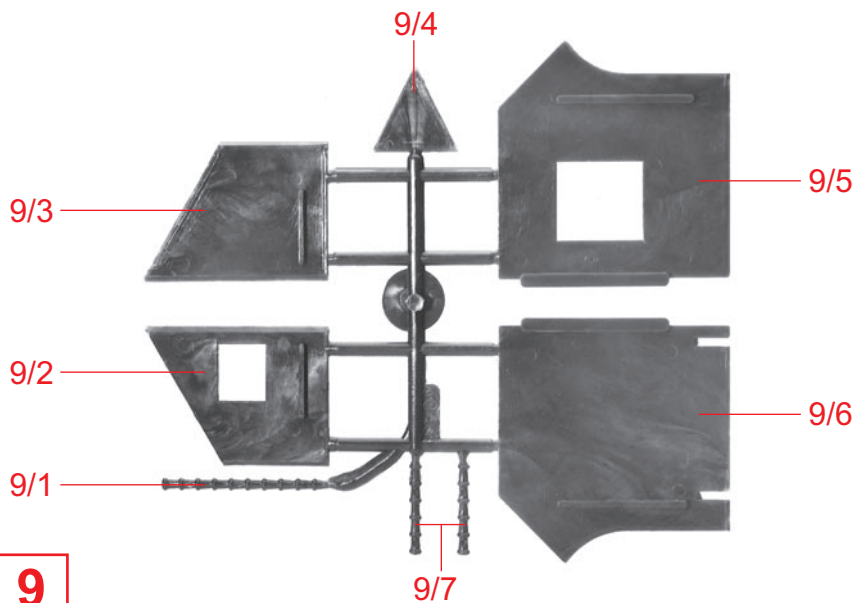

9

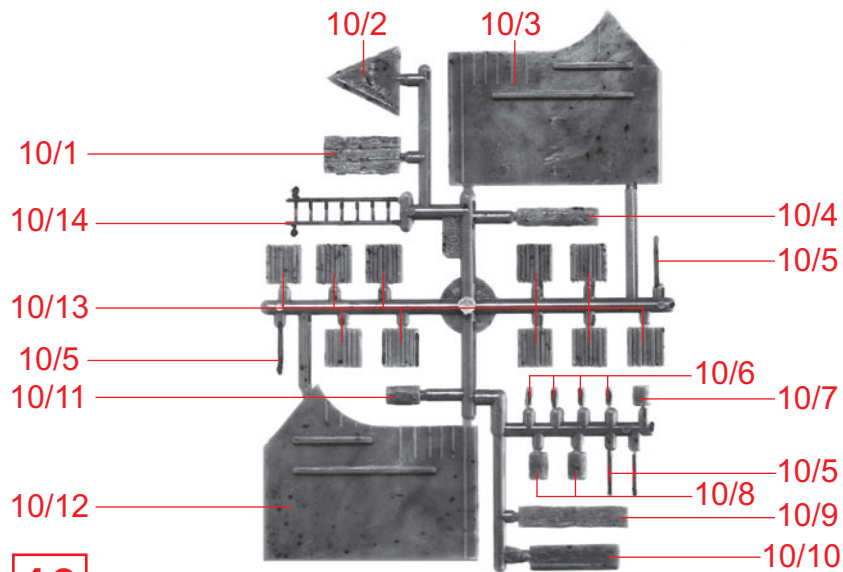

10

8

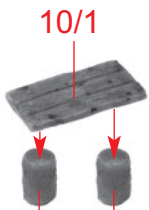

(R) 10/8

5/9

9/2

(S)

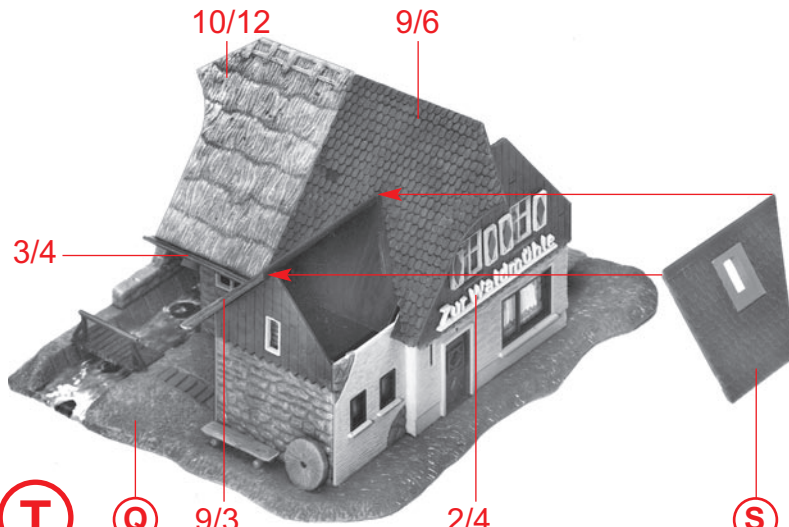
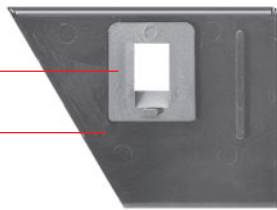

(T)

(Q)

9/3

2/4

(S)

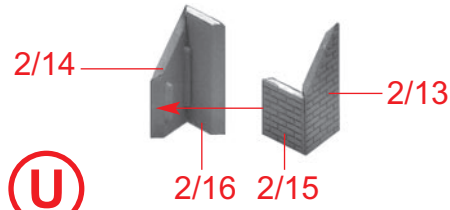

(U)

2/16

2/15

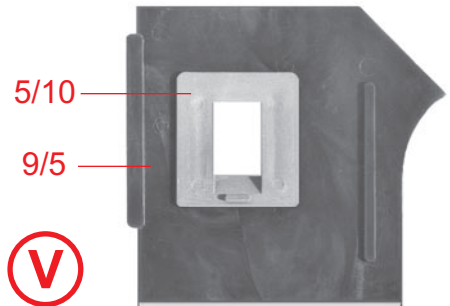

(V)

5/10

9/5

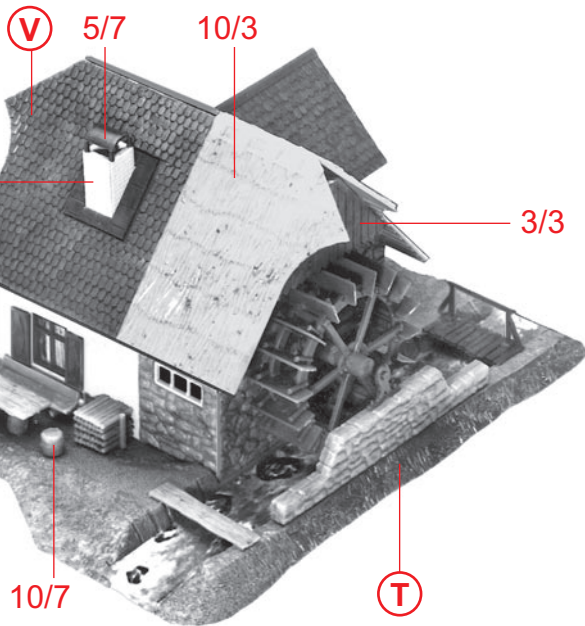

(V)

5/7

10/3

3/3

(U)

10/11

(R)

10/7

(T)

(W)

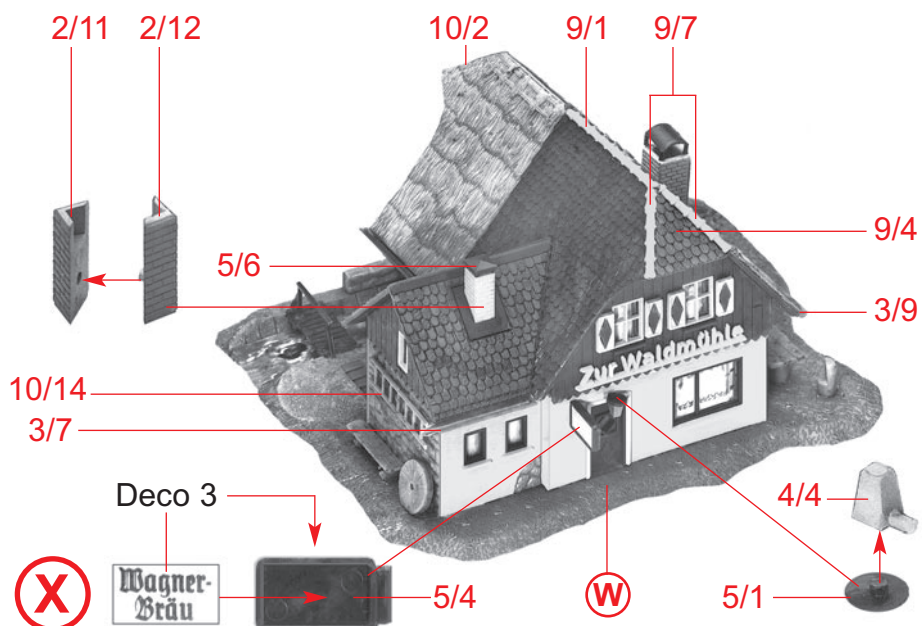

2/11

2/12

10/2

9/1

9/7

9/4

3/9

5/6

10/14

3/7

Deco 3

Wagner-Bräu

5/4

4/4

5/1

(X)

(W)